



# PLC ACCESS SYSTEM STANDARDIZATION PROCESS

10th June 2003

0



## INTRODUCTION

PUA, as an alliance of major european utilities,  
are willing  
to deploy PLC systems commercially.

1

## INTRODUCTION

- Key improvements have to be added to the current technologies.
  - *Today, there is no “universal” solution. In the short term, PUA members will most likely roll out choosing different technologies according to their specific technical and market conditions.*
  - *Several key improvements are needed until all PUA members roll out the same technology on a large scale.*

2

## INTRODUCTION

- Significant cost reductions are needed.
  - *Economies of scale shall be achieved. The same chipsets shall be used by different system integrators.*
  - *Competition between manufacturers at the different levels of the supply chain (chipsets, products and system) shall be favoured.*
- Interoperability between units from different manufacturers is mandatory.

3



## INTRODUCTION

Go fast !

Since alternative technologies  
are developing every day more !

4



## OBJECTIVE

PUA members have decided  
to define and promote  
an **open PLC access standard**  
**as soon as possible**

5

## SCOPE OF THE ELEMENTS TO BE STANDARDIZED

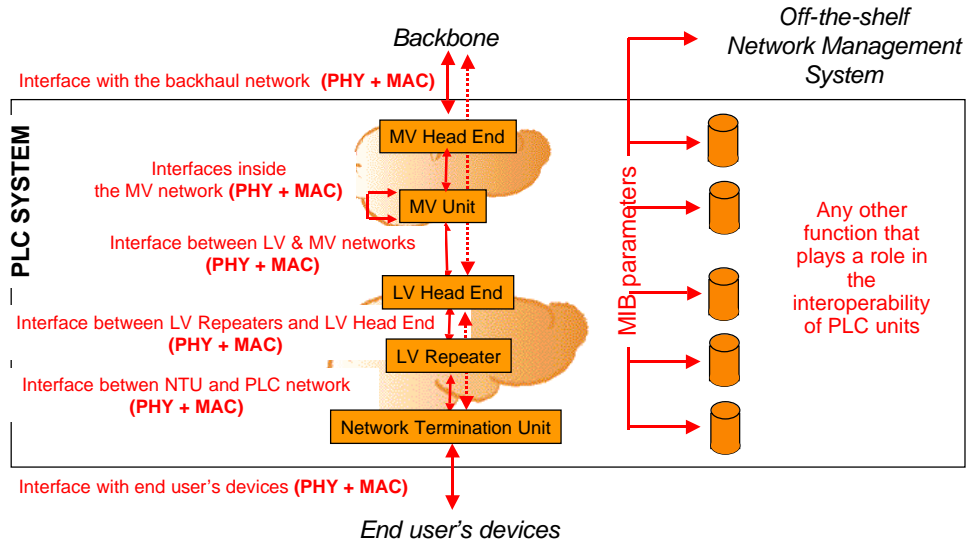

6

## DEFINITION OF THE PROCESS

- A fast process, organized as an evaluation process.
- Looking at the new generation products or prototypes that will be available in the next months.

7



# STANDARDIZATION PROCESS

